

Powerdrive E

Original instructions

921A

EN

CE



LIFT-O-FLEX

MOBI-Crane  Voyager

EC declaration of conformity of the machinery / EG-försäkran om maskinens överensstämmelse

According to the Machinery Directive 2006/42/EC, Annex II A / I enlighet med EU:s Maskindirektiv 2006/42/EG, Bilaga II A

Manufacturer / Tillverkare:

Denomination / Benämning:	Machine type / Maskintyp:	Type / Typ:
Powerdrive	Driving unit Åkverk	ADU1-2 ADU3

Applied EC guidelines / Tillämpade EG-riktlinjer:

2006/42/EC	Machinery Directive / Maskindirektivet
2006/95/EC	Low Voltage Directive / Lågspänningsdirektivet
2004/108/EC	EMC Directive / EMC-direktivet

KRISTIANSTAD 2010-02-09

(Place and date)

(Signature)

Staffan Nilsson

Name:

Head of engineering department / Konstruktionschef

Position:

Although the greatest care was taken regarding the information in this publication, we assume no responsibility for any errors. We reserve the right to make changes.

ILLUSTRATIONS – The illustrations in the publication represent the described products, but the delivered goods may differ in some respects from the illustrations.

SPECIFICATIONS – The right is reserved to make changes in design and dimensions compared with the information in the publication in order not to prevent development of designs, material and manufacturing methods.

The customer is reminded that in the purchase of Movomech's products for application on the job or elsewhere, there is supplementary, current information that could not be included in the publication in terms of recommendations on each product's suitability regarding different combinations of RonI's comprehensive product line.

All relevant information must be provided to the persons who are responsible for the application of the product.

Contents

1 Safety	4
2 Technical data	6
AHB1.1-2.....	6
AHB3	8
Control unit	10
3 Electrical installation.....	11
3.1 SIEMENS Single.....	11
3.2 SIEMENS Single + Transit power supply to other equipment	12
3.3 SIEMENS Double	13
3.4 SIEMENS Double + Transit power supply to other equipment.....	14
3.5 SIEMENS Triple	15
3.6 SIEMENS Control units.....	16
3.7 LUST Single	17
3.8 LUST Single + Transit power supply to other equipment.....	18
3.9 LUST Double.....	19
3.10 LUST Double + Transit power supply to other equipment	20
3.11 LUST Triple (1/2).....	21
3.12 LUST Triple + Transit power supply to other equipment (1/2)	22
3.13 LUST Triple (2/2).....	23
4 Service and maintenance	24
4.1 Service record	25
4.2 Troubleshooting.....	27

1 Safety

RonI's equipment is manufactured in accordance with the latest technological advances.

All products are manufactured according to the latest European standards, e.g. EG Machinery Directive (MD) 98/37/EG

The aim of this documentation is to provide the user with practical instructions for safe operation and simple maintenance of the equipment.

Anyone who deals with the installation of the equipment (including related equipment), operational procedure, use, maintenance, and/or repair functions must have read and understood:

- The instruction manual
- The safety regulations
- The safety instructions for each individual section.

In order to avoid misuse and to ensure the reliable operation of the products, we recommend that the instruction manual is always available to the user/operator.

Intended usage

The equipment is intended exclusively for transportation, lifting and lowering of load. Any other use, including the towing of a load and the transportation of passengers, is prohibited (see below for more examples).

RonI does not accept responsibility for damage caused by such use. All risks are the sole responsibility of the user.

The equipment may only be used in perfect technical condition by trained staff, and in accordance with current safety and work protection regulations. Furthermore, the user must observe operational and maintenance conditions contained in the instruction manual.

Severe personal injury and damage to equipment can be caused by:

- Removal of covers and casings
- Non-professional installation of equipment
- Incorrect usage
- Insufficient maintenance

Prohibited usage

Certain types of activities and operations are prohibited, as in specific circumstances they can cause personal injury as well as permanent damage to the construction.

For example:

- It is prohibited to convey passengers using the equipment.
- Never transport suspended loads above anyone's head.
- Never drop a suspended load, and make sure it is lifted in a straight line.
- Never loosen secured or fastened loads by using the equipment.
- Do not overload.
- Do not leave a suspended load unattended.

General safety aspects

The instruction manual should always be kept within easy reach of the equipment. It contains important safety information and sections that relate to guidelines, norms, and regulations.

Failure to follow the safety regulations in this instruction manual may result in personal injury or death.

In addition to the instruction manual, generally applicable regulations and rules must be followed and adhered to in order to avoid accidents and protect the environment.

This also applies to regulations relating to the handling of products dangerous to the environment and the use of personal safety equipment.

As regards all work associated directly or indirectly with the equipment, the user must follow and adhere to all the above regulations as well as current work protection and safety regulations.

In spite of this, a life-threatening risk still prevails in cases where the equipment is used and operated by non-trained or non-instructed staff in a non-professional or non-intended way.

The user should supplement the instruction manual with instructions that consider the nature of the operation, e.g. company organisation, work procedures, and number of staff.

The members of staff who are assigned to work with the equipment must have read the instruction manual prior to undertaking any work, and he/she should pay particular attention to the chapters containing safety instructions.

It is too late once work has commenced.

This applies in particular to members of staff who are working with the equipment on a temporary basis, e.g. for maintenance purposes.

When convenient, the staff should be tested on their knowledge of the manual's contents that relate to safety and accident awareness. The user is responsible for ensuring that the equipment is used only when it is in perfect condition and that all applicable and relevant safety regulations and requirements are followed.

The equipment should be taken out of operation immediately if functional damage or defects are discovered. Personal safety equipment should be used as and when necessary, or when required by regulations. Safety and warning devices, such as signs, stickers and labels must not be removed or made illegible.

All safety and warning devices on or adjacent to the equipment should be complete and maintained in a legible/functional condition.

All changes, extensions or reconstruction that may affect safety are forbidden without written permission from RonI. This also applies to assembly and adjustment of safety equipment and welding of structural parts.

Spare parts must comply with RonI AB's stated technical requirements. This compliance is guaranteed when original spare parts are used. The intervals prescribed or stated in the instruction manual for regular testing/inspection must be adhered to!

Staff selection and qualifications

Reliable staff must carry out work with/on the equipment. Regulations that apply to under-age persons must be followed.

The user is responsible for supplying necessary training and instructions to those that he/she employs, including professionals and/or apprentices.

It is recommended that the user draws up instructions and guidelines relating to the causes of errors, communicates these to the relevant staff, and posts directions on appropriate and clearly visible places. It is recommended that the user makes sure that the knowledge of the staff is adequate as regards the following points, prior to the operation of the construction:

- Knowledge of the contents of the instruction manual
- Knowledge of the safety and user regulations contained therein
- Knowledge of applicable work protection regulations

Only trained and instructed staff should be permitted to work with the equipment. Parameters relating to use, maintenance, and installation should be clarified.

Safety instructions for usage

The only persons allowed to work on the electrical equipment are

competent staff members who work in accordance with regulations and standards for high-voltage equipment.

No persons under the influence of drugs, alcohol or medication which affects their ability to react, are allowed to use, maintain, or repair the construction.

All stated actions and instructions relating to work protection and issues relating to general safety and protection of workers that should be carried out or studied prior to, during or following operation must be followed to the letter.

Failure to do so may result in fatal accidents.

The equipment should be stopped or taken out of operation at the time of detection of faults relating to work protection and operational accessibility.

Safety equipment must not be deactivated, altered or used in a way that conflicts with applicable regulations.

Appropriate actions must be taken to ensure safe operation and functional conditions for the user.

The equipment should only be used when all protective and safety equipment, such as detachable guards and emergency stop devices, are in place and in working order.

Any type of modification and alteration of the equipment is prohibited.

However, this does not apply to lesser changes that do not affect the strength, operational safety or work protection, or to actions which promote an increased level of safety.

The fundamental responsibility for these changes lies with the user. If in doubt, contact RonI for written approval of the actions prior to implementation.

The equipment should be stopped and locked immediately when functional faults occur.

Faults should be corrected immediately.

A person who detects an immediate danger must without delay press the emergency stop button. This also applies to damage to parts of the equipment that demand immediate stoppage of operation.

Following an "emergency stop" the user has to wait for the cause of the disruption to be repaired and for an assurance that there is no further danger before he/she reconnects the equipment and resumes operation.

The equipment should be disconnected immediately in the following cases:

- When electrical equipment, cables, and/or insulation material is damaged
- When brake functions and/or safety equipment are defect

Specific local circumstances or applications may lead to situations that were unknown at the time of writing this document.

In such cases, the user must ensure safe operation and disconnect the equipment until measures to maintain safe operation have been carried out in conjunction with RonI or other authorised party.

Ensure that no one can become injured when they use the equipment prior to connecting/activating the equipment.

If the user notices the presence of persons who may become injured during operation, the operation should be discontinued immediately and must not be resumed until these persons have left the dangerous area.

The user must make sure that the equipment is in a perfect and operationally safe condition prior to all operations using the equipment.

The user should carry out all prescribed safety measures and make sure that automated procedures are completed when the equipment is disconnected (e.g. when there are deficiencies as regards operational and personal safety, an emergency situation exists, repair or maintenance is being carried out, damage is noticed or at the completion of work).

Work with the equipment is only allowed when the operator has been instructed to do so by his superior, and if the operator has knowledge of the equipment and its function.

2 Technical data

Traversing speed	m/min	40
Noise level	dB (A)	<70
Tare weight	kg	<17
Motor output	kW	0,18
Voltage	V	*
Fuse	AT	10
Enclosure class	IP	54

*		
Single		1*230, N, PE (±15) 50/60 Hz
Single + Slave		3*400, N, PE (±15) 50/60 Hz
Double		1*230, N, PE (±15) 50/60 Hz
Double + Slave		3*400, N, PE (±15) 50/60 Hz
Triple		3*400, N, PE (±15) 50/60 Hz

AHB1.1-2

730814

Max load: 250 kg

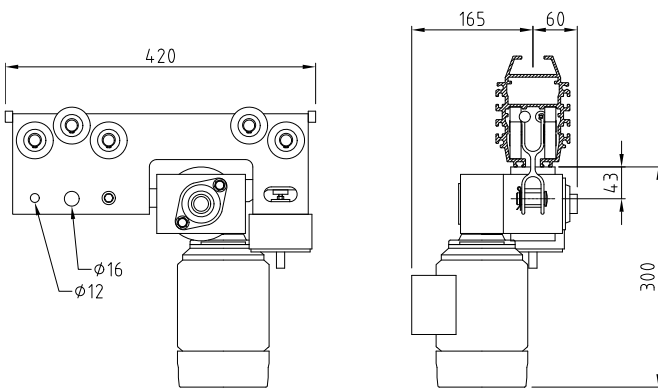

734669

Max load: 250 kg

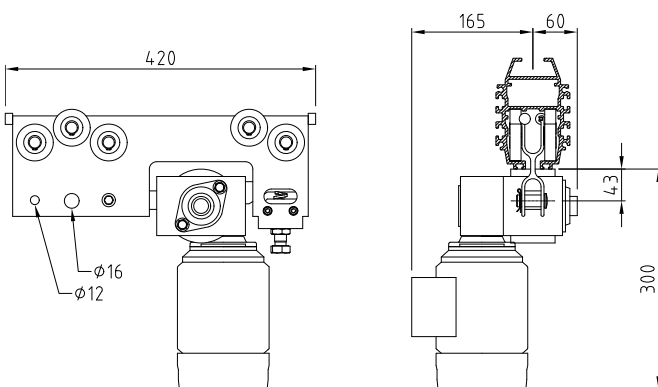

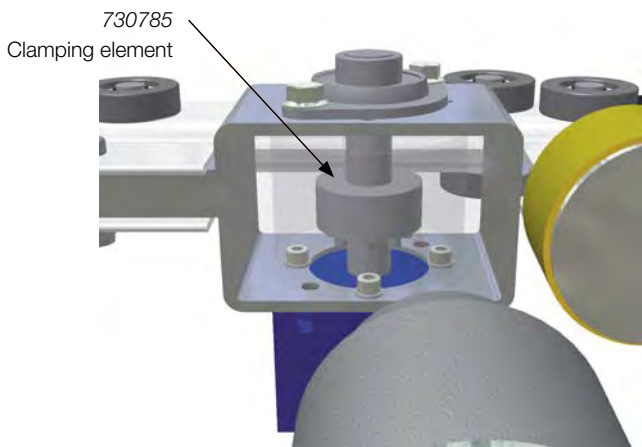
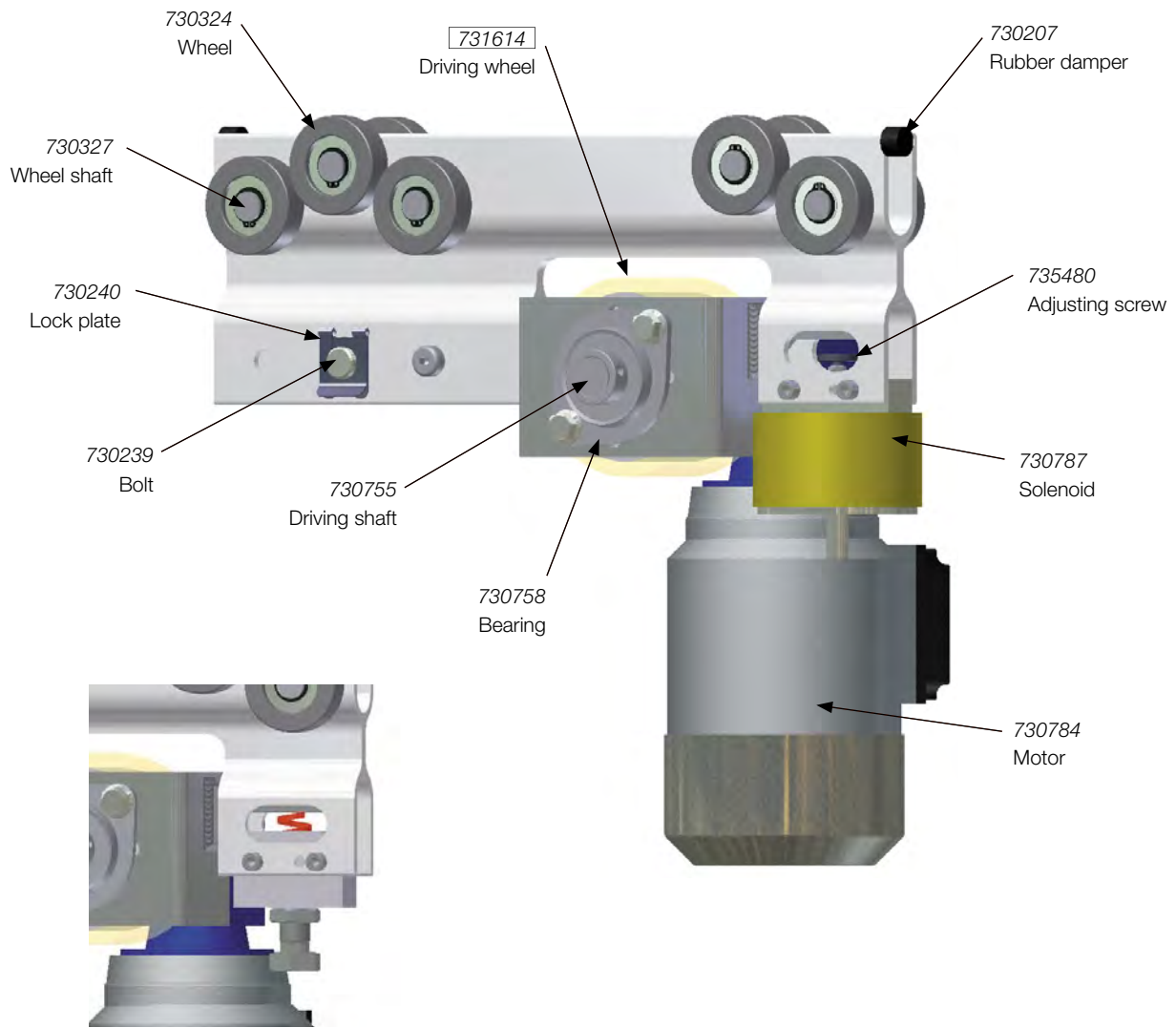

AHB1.1

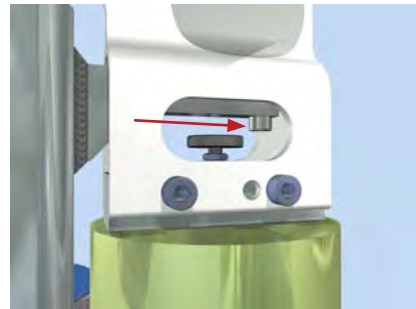

AHB2

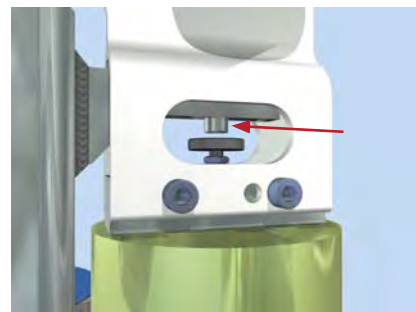

= Recommended sparepart

* = Article rated as wear part

AHB3

731630

Max load: 500 kg

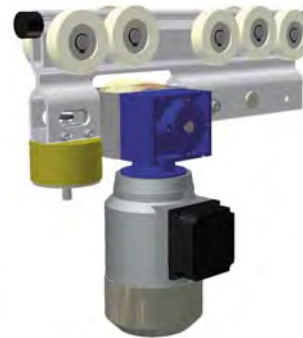
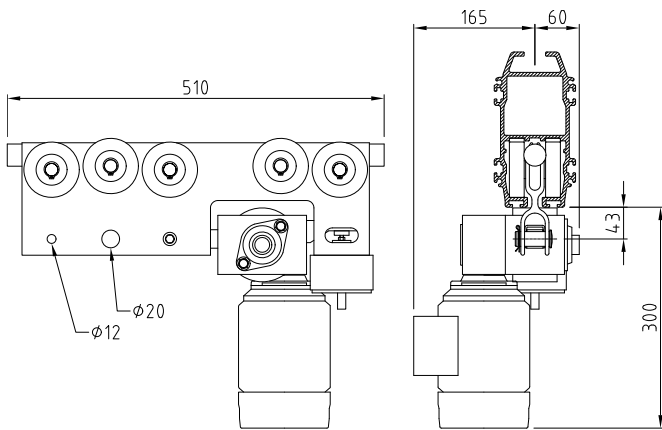

734671

Max load: 500 kg

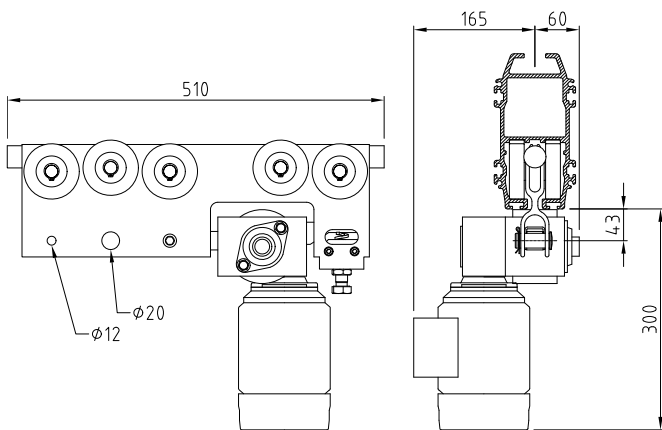

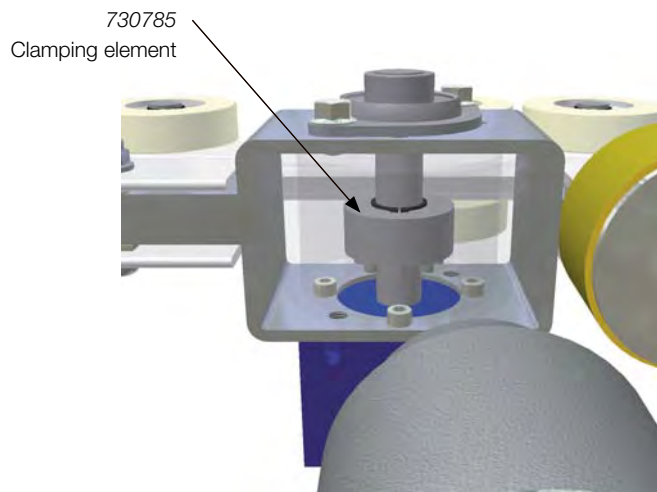
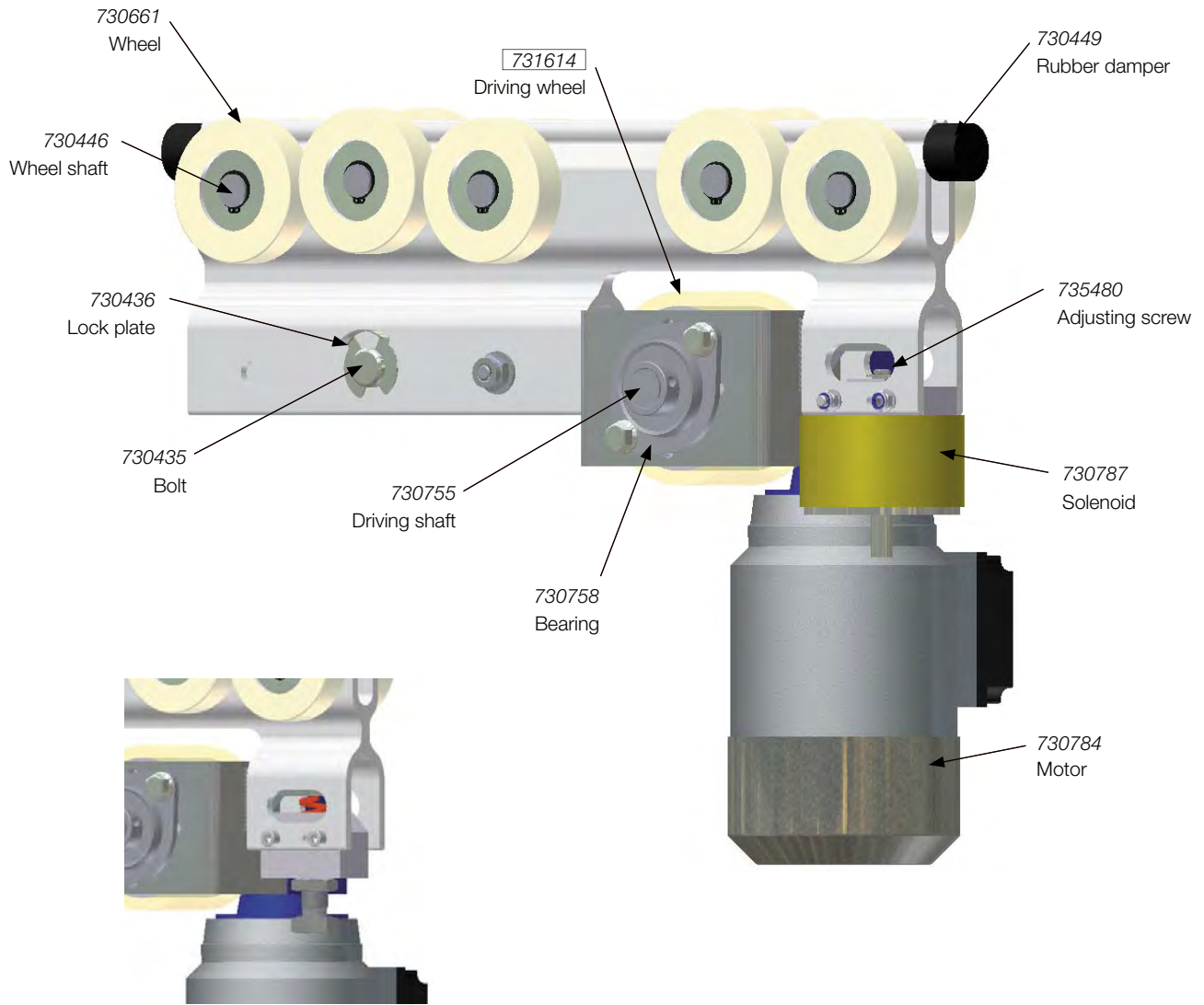

= Recommended sparepart

* = Article rated as wear part

Handling

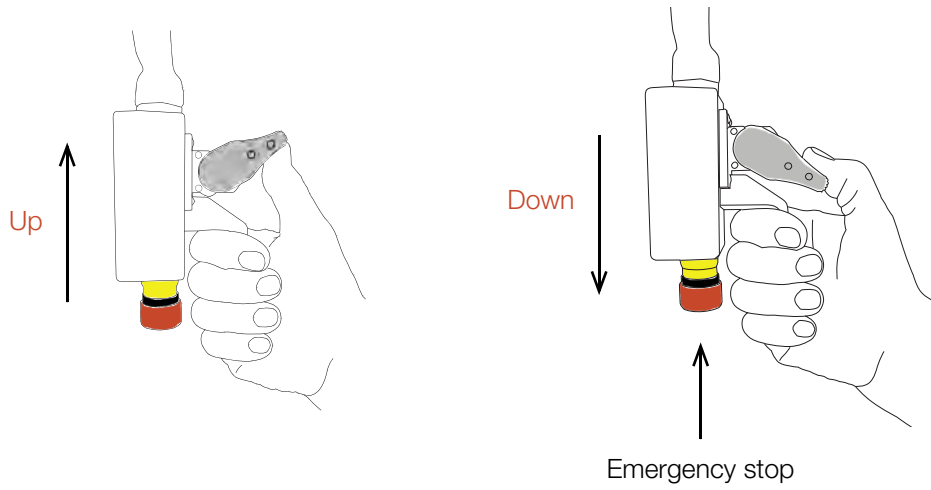

Control unit

732314 ↔

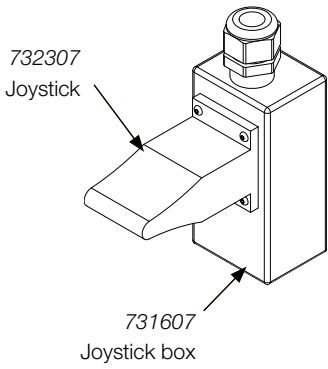

731601 ↔

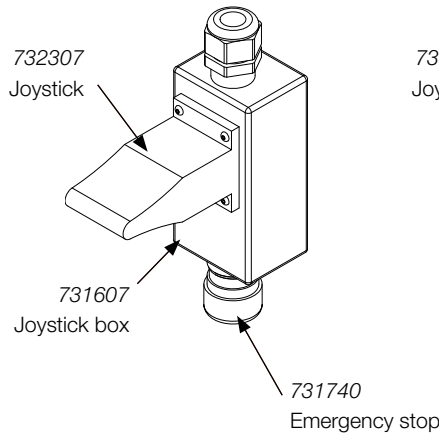

731599 ↔

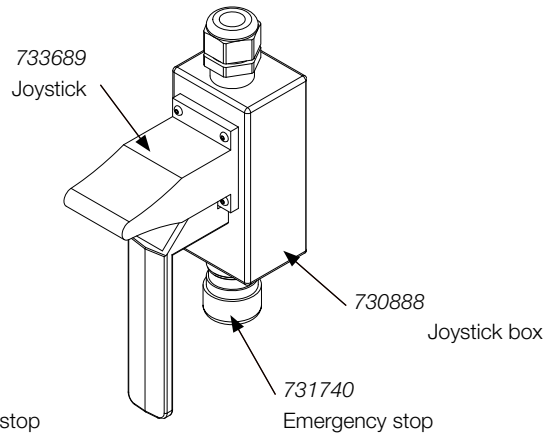

734639 ↔



735618 ↔

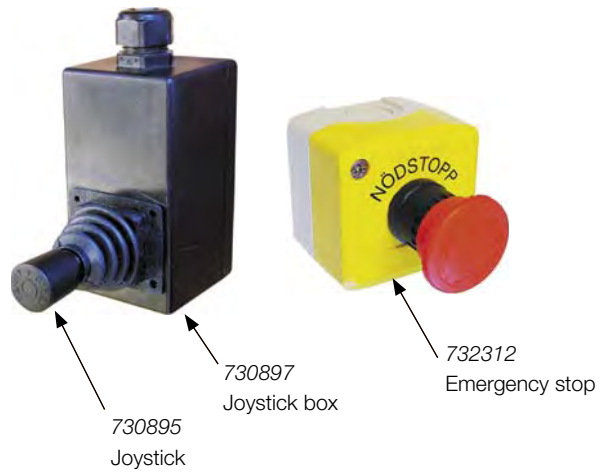

3 Electrical installation

3.1 SIEMENS Single

735615

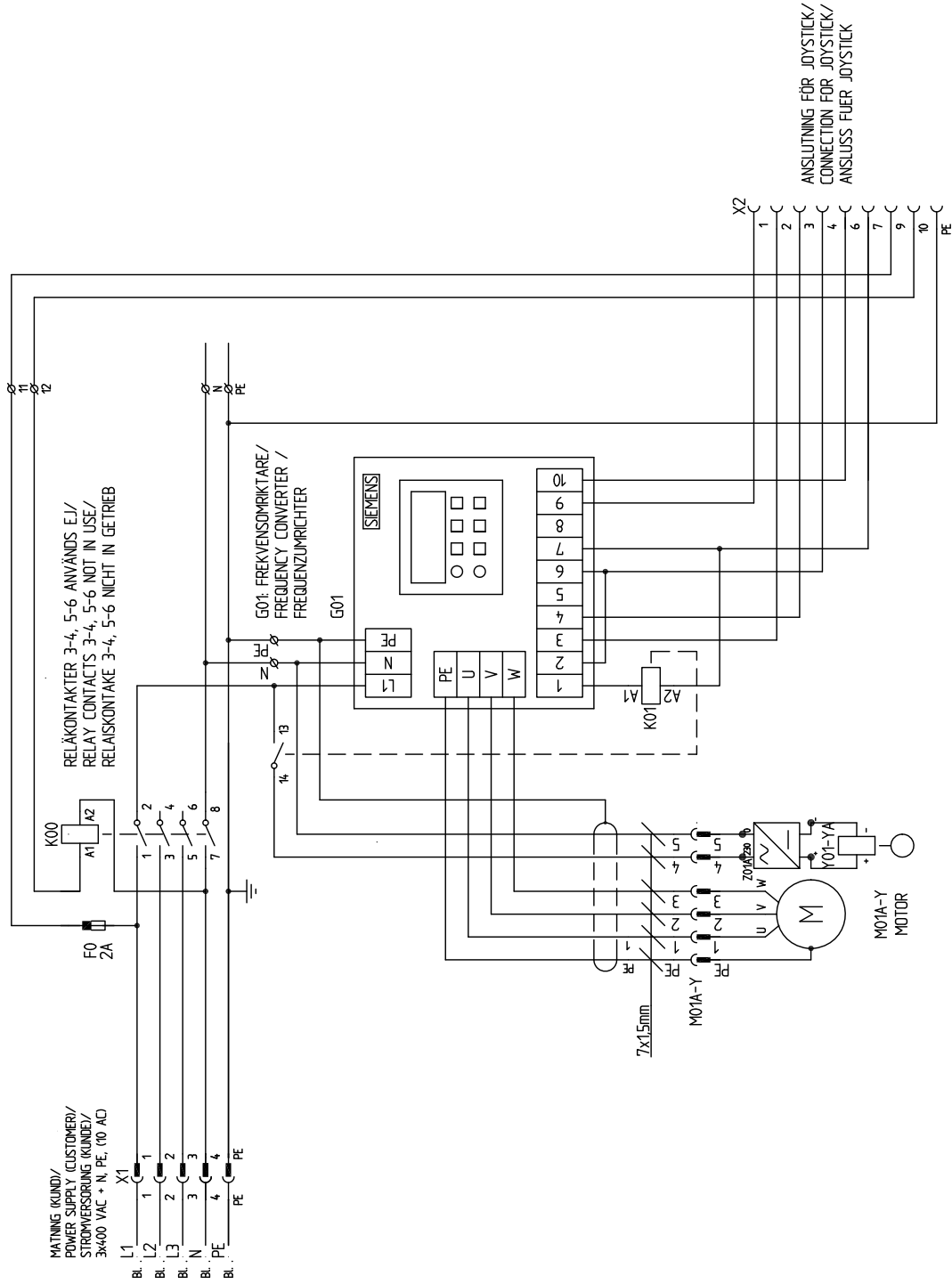

- G01 737289
- K00 730790
- K01 730791
- F0 733272

Powerdrive electric

3.2 SIEMENS Single + Transit power supply to other equipment

735615

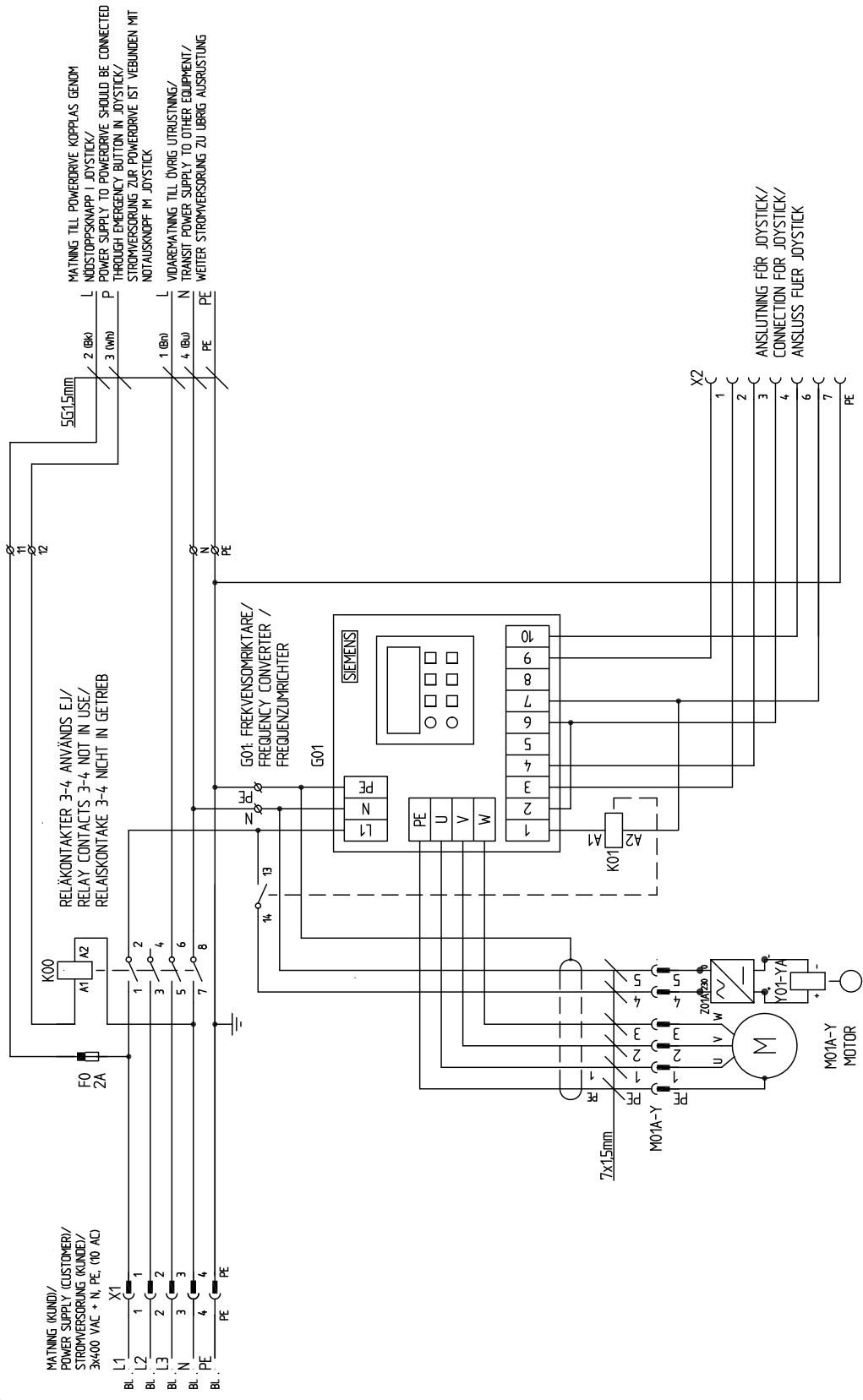

- G01 737289
- K00 730790
- K01 730791
- F0 739272

3.3 SIEMENS Double

735616

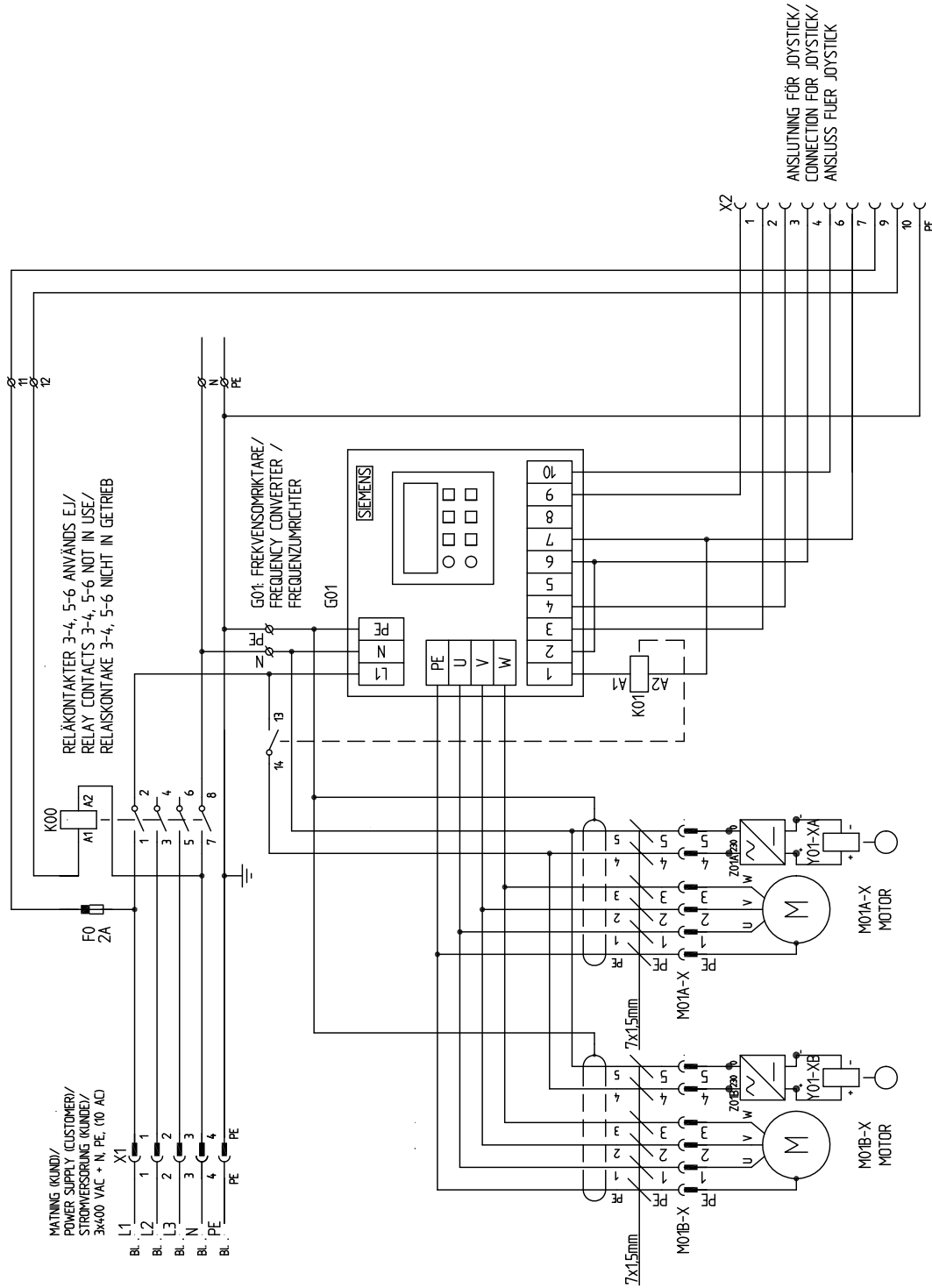

- G01 737289
- K00 730790
- K01 730791
- F0 733272

3.4 SIEMENS Double + Transit power supply to other equipment

735616

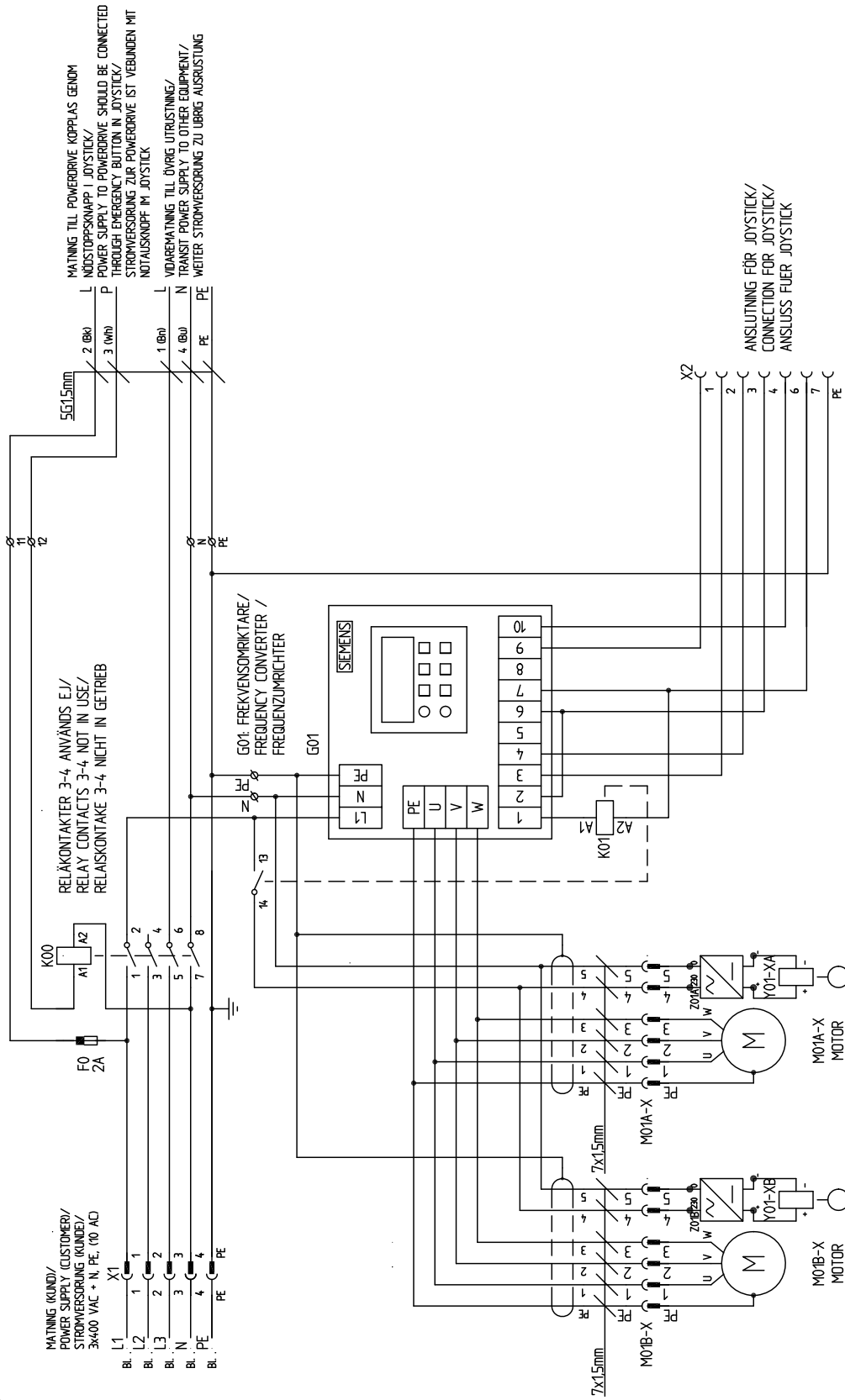

- G01 737289
- K00 730790
- K01 730791
- F0 739272

3.5 SIEMENS Triple

735617

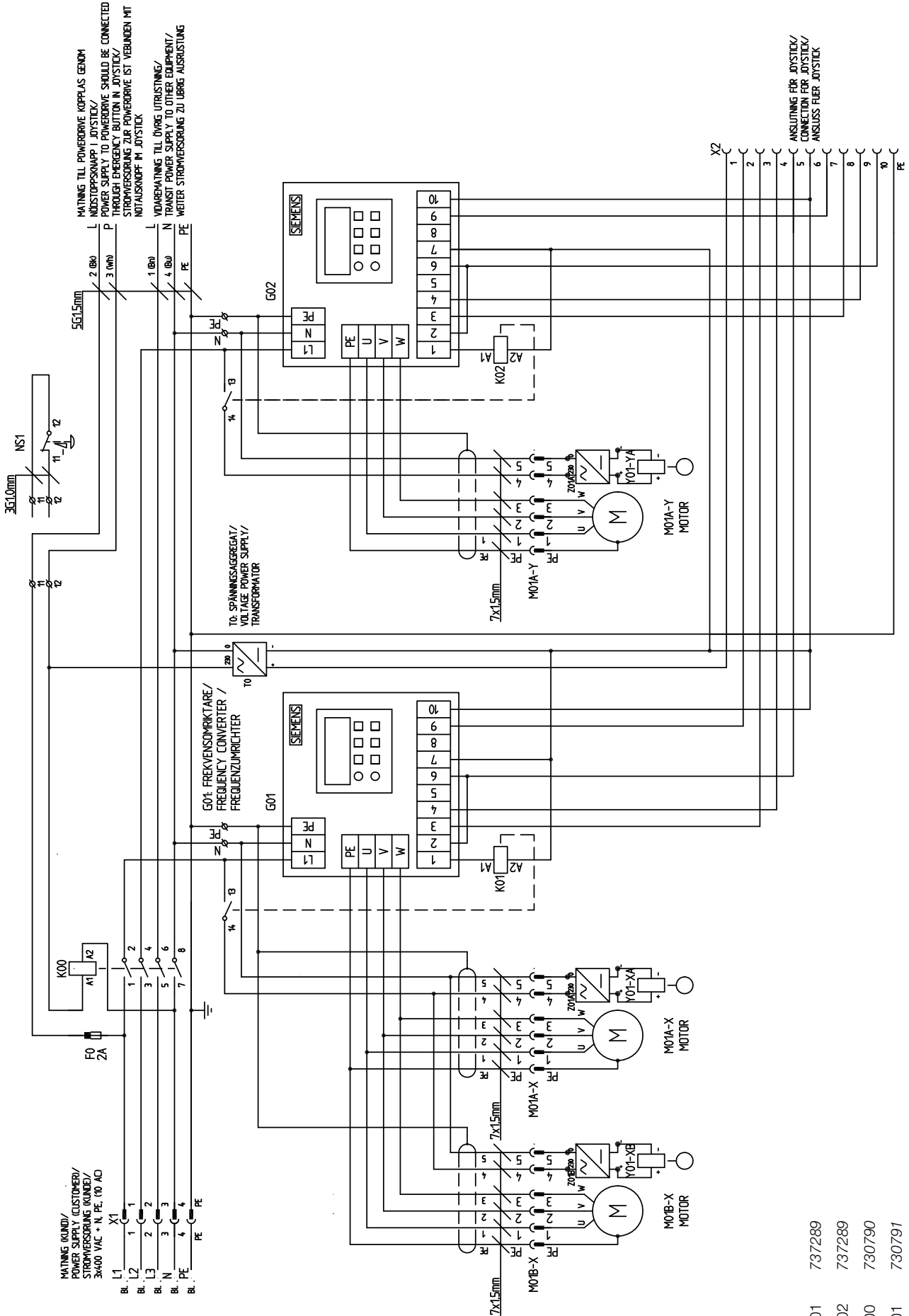

- G01 737289
- G02 737289
- K00 730790
- K01 730791
- K02 730791
- F0 733272

Powerdrive electric

3.6 SIEMENS Control units

732314

ANSLUTNING TILL HUVUDSKÅP/
CONNECTION TO MAIN CABINET/
ANSLUSS ZU HAUPSCHRANK/

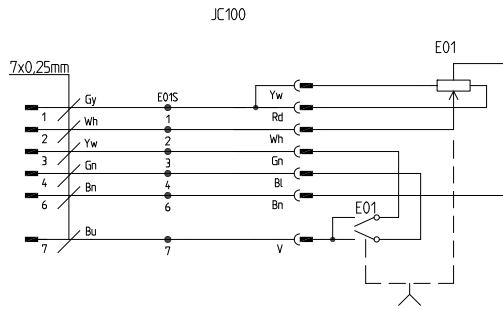

731599, 731601

ANSLUTNING TILL HUVUDSKÅP/
CONNECTION TO MAIN CABINET/
ANSLUSS ZU HAUPSCHRANK/

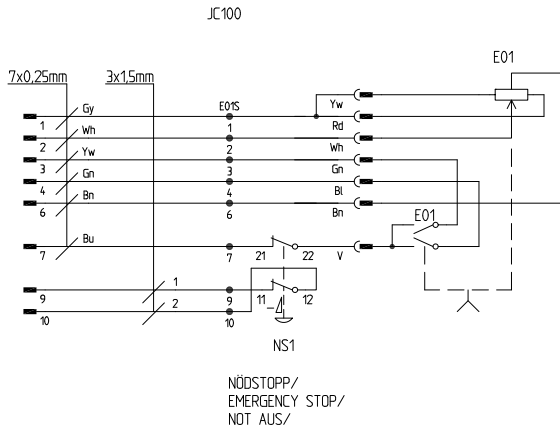

NÖDSTOPP/
EMERGENCY STOP/
NOT AUS/

734639, 735618

ANSLUTNING TILL HUVUDSKÅP/
CONNECTION TO MAIN CABINET/
ANSLUSS ZU HAUPSCHRANK/

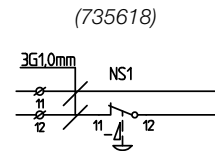
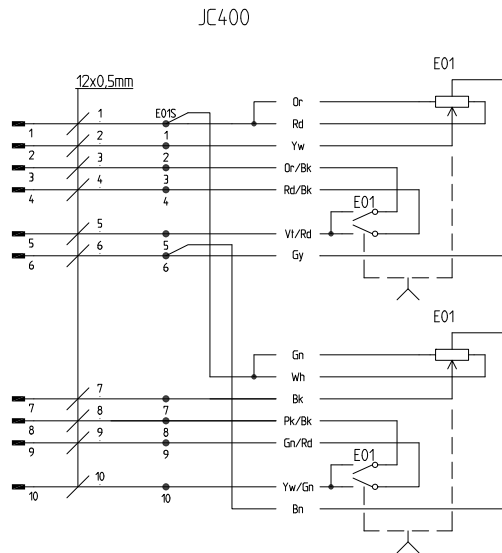

3.7 LUST Single

737642

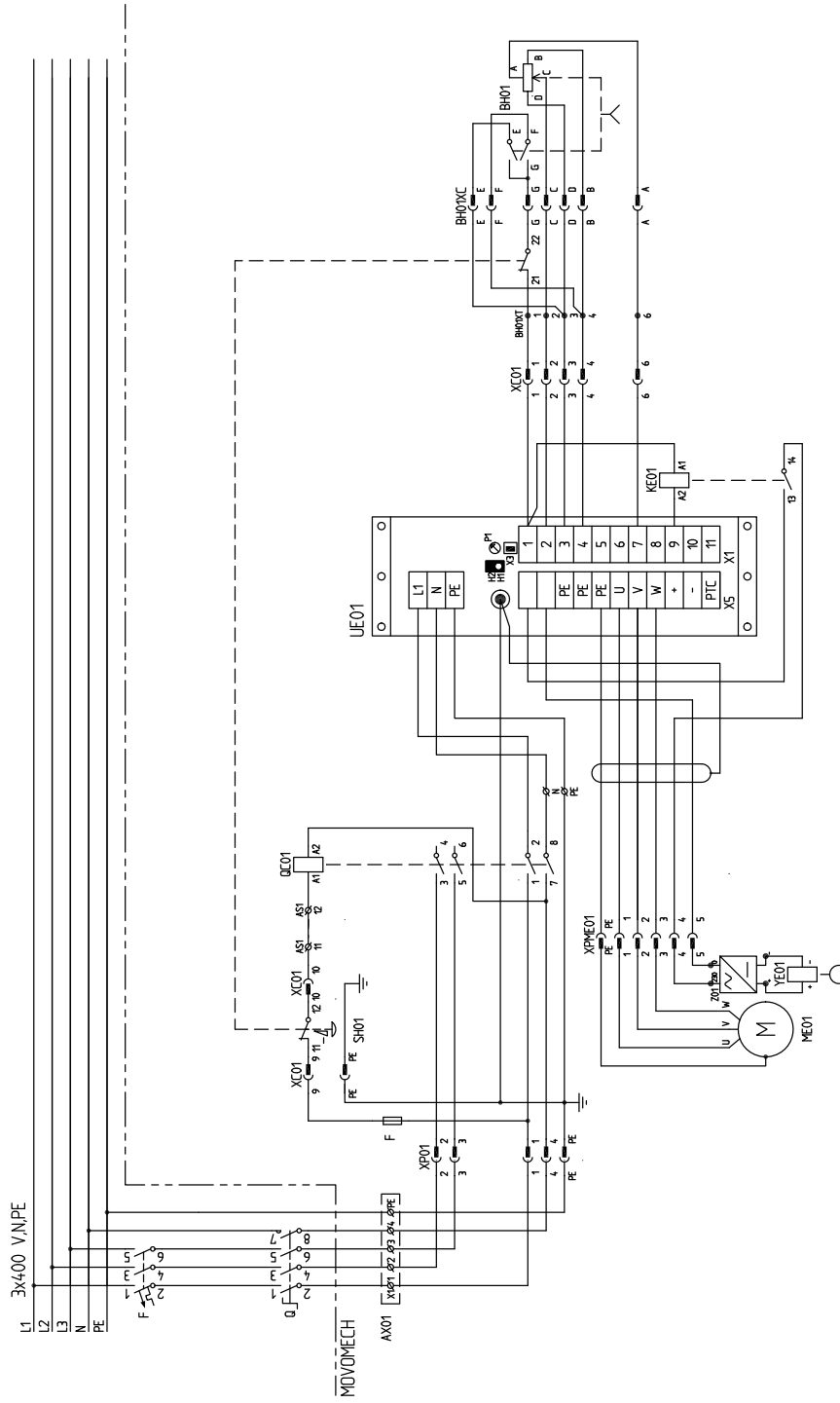

- UE01 730792
- QC01 730790
- KE01 730791
- F 733272

Powerdrive electric

3.8 LUST Single + Transit power supply to other equipment

737642

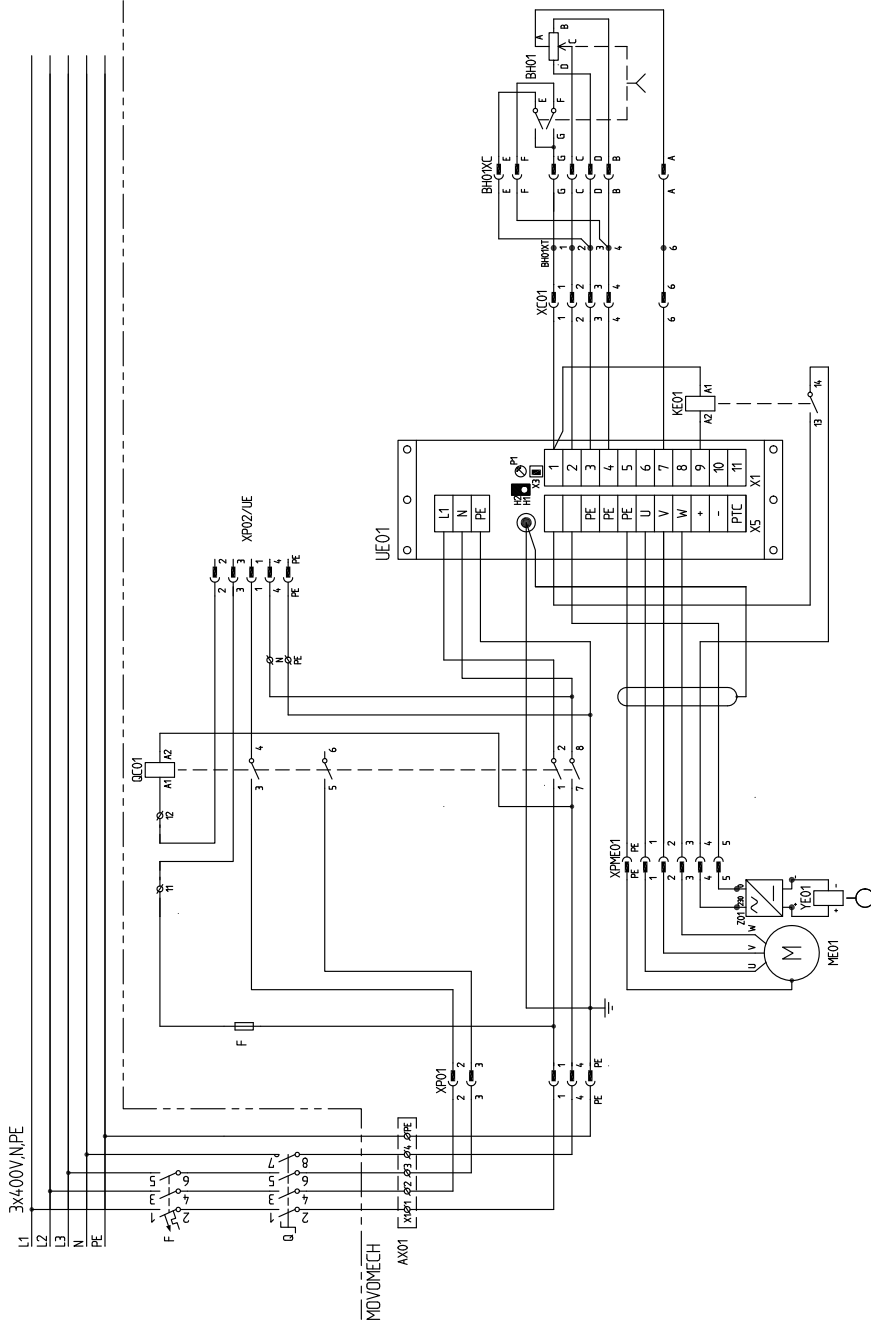

- UE01 730792
- QC01 730790
- KE01 730791
- F 733272

3.9 LUST Double

737643

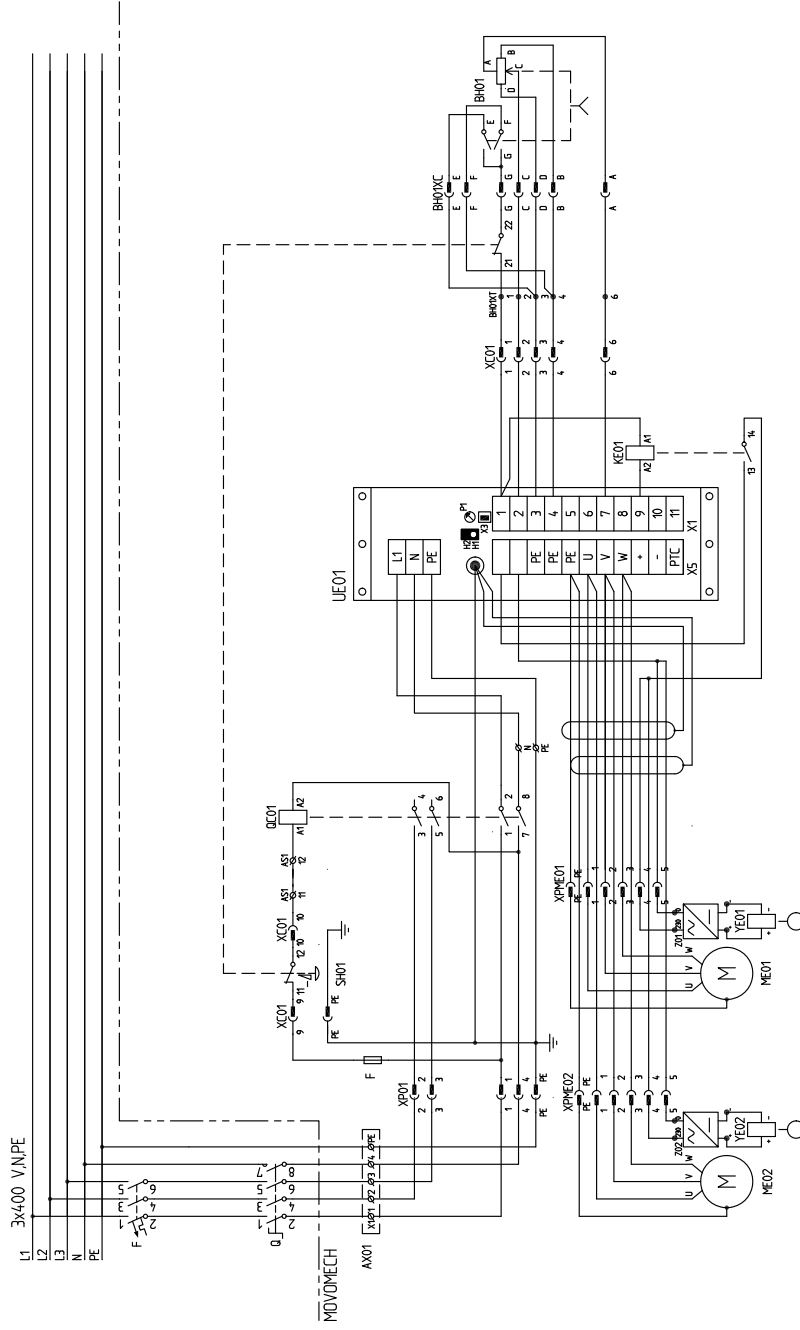

- UE01 730792
- QC01 730790
- KE01 730791
- F 733272

Powerdrive electric

3.10 LUST Double + Transit power supply to other equipment

737643

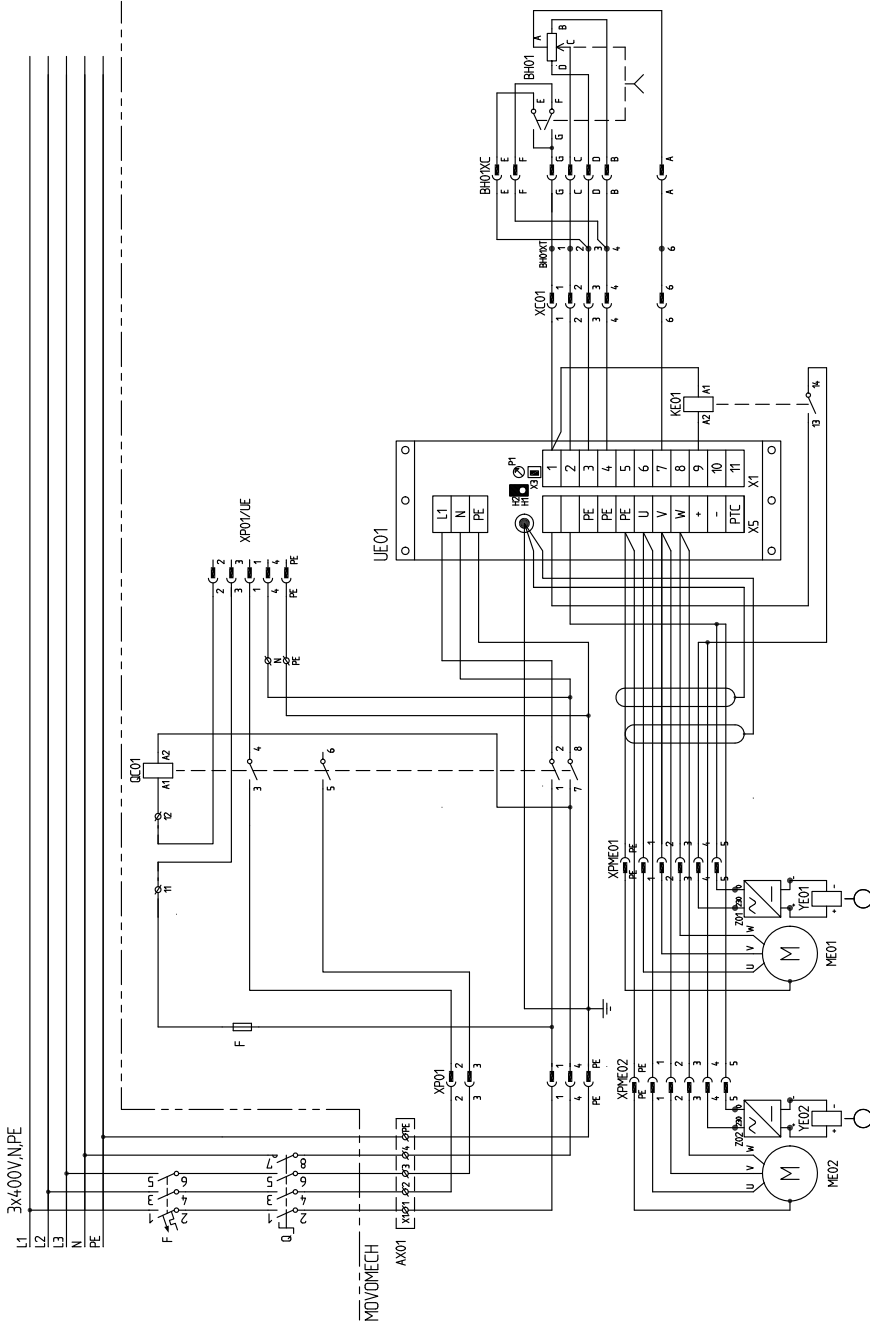

- UE01 730792
- QC01 730790
- KE01 730791
- F 733272

3.11 LUST Triple (1/2)

737644

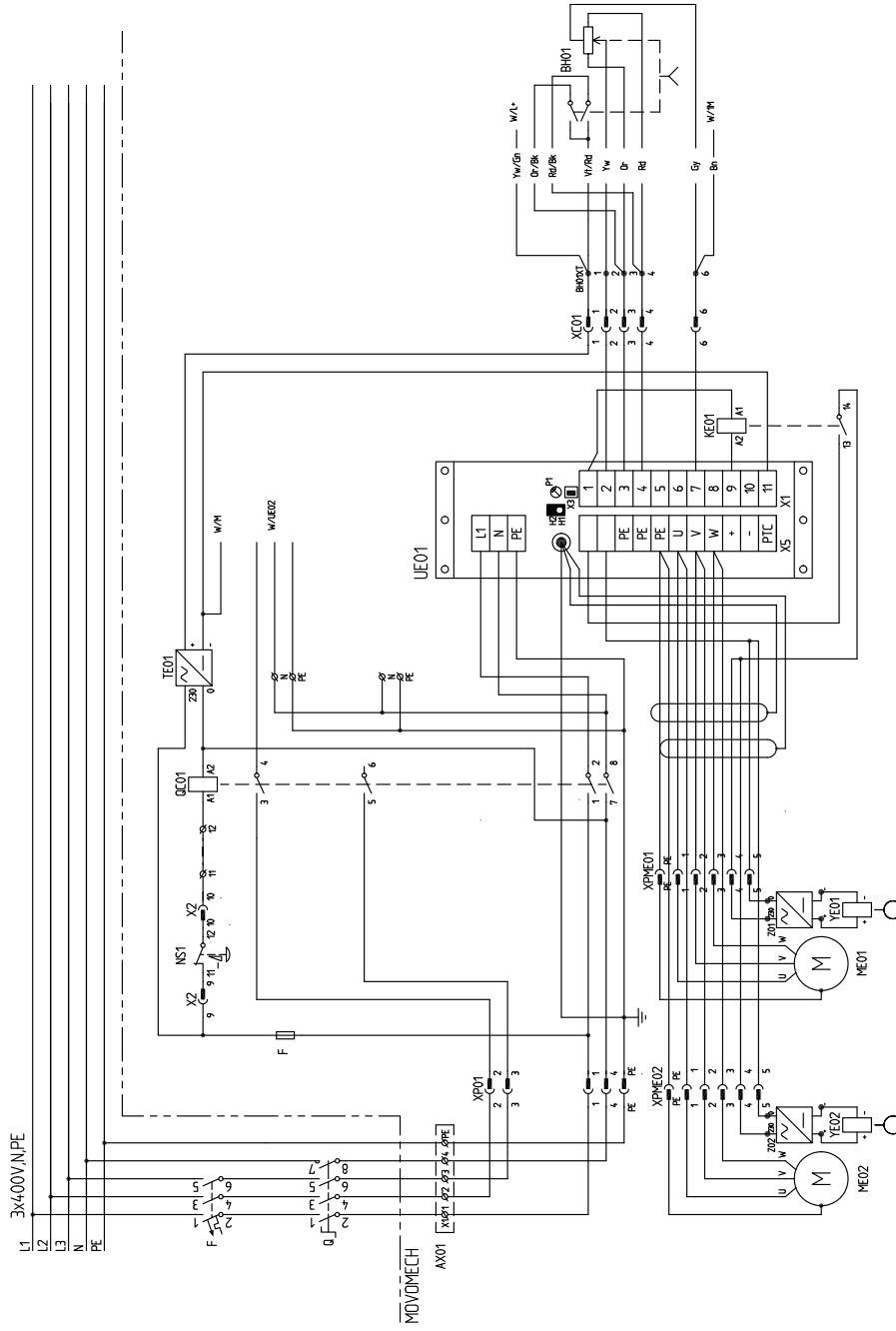

- UE01 730792
- QC01 730790
- KE01 730791
- F 733272

Powerdrive electric

3.12 LUST Triple + Transit power supply to other equipment (1/2)

737644

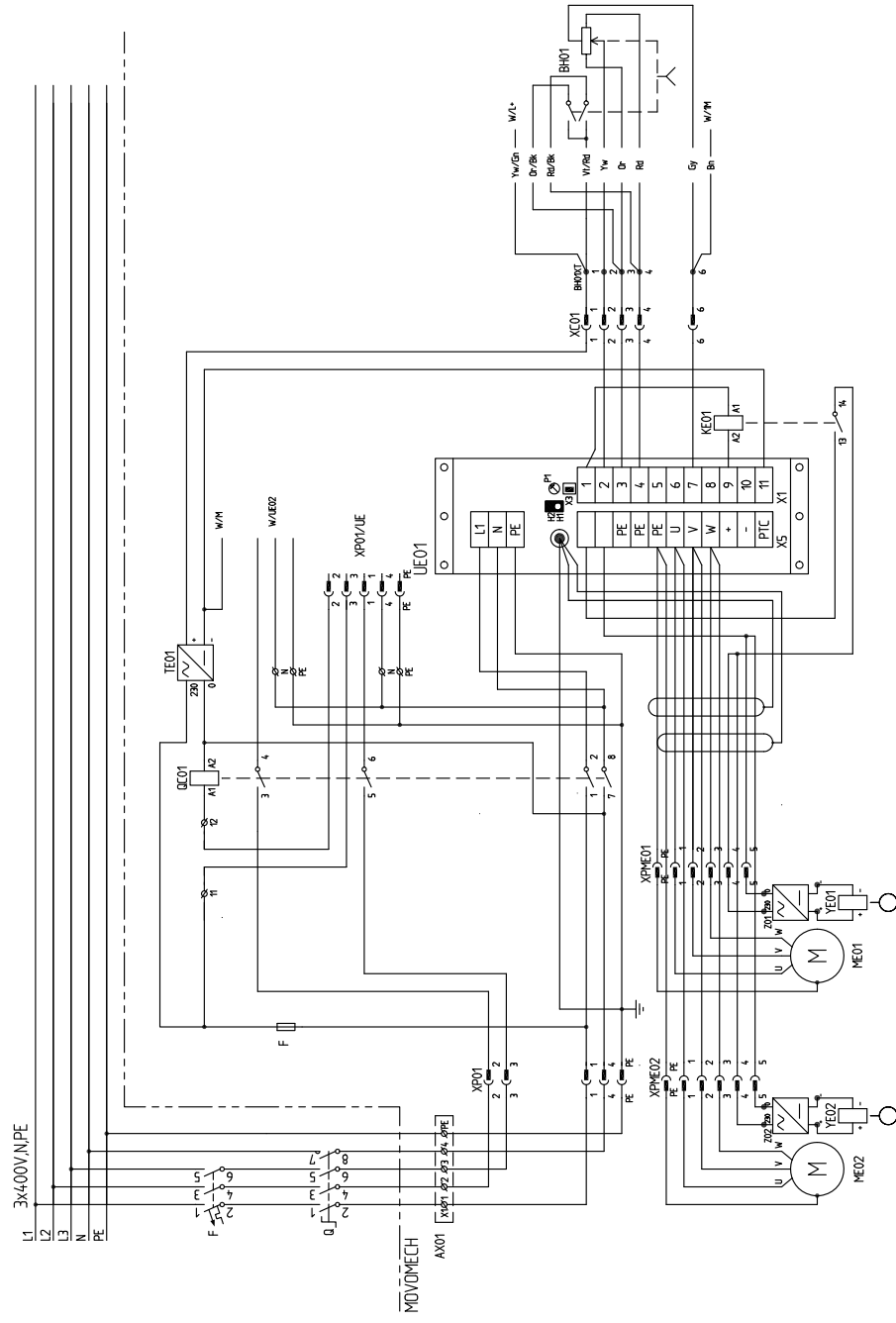

- UE01 730792
- QC01 730790
- KE01 730791
- F 733272

3.13 LUST Triple (2/2)

737644

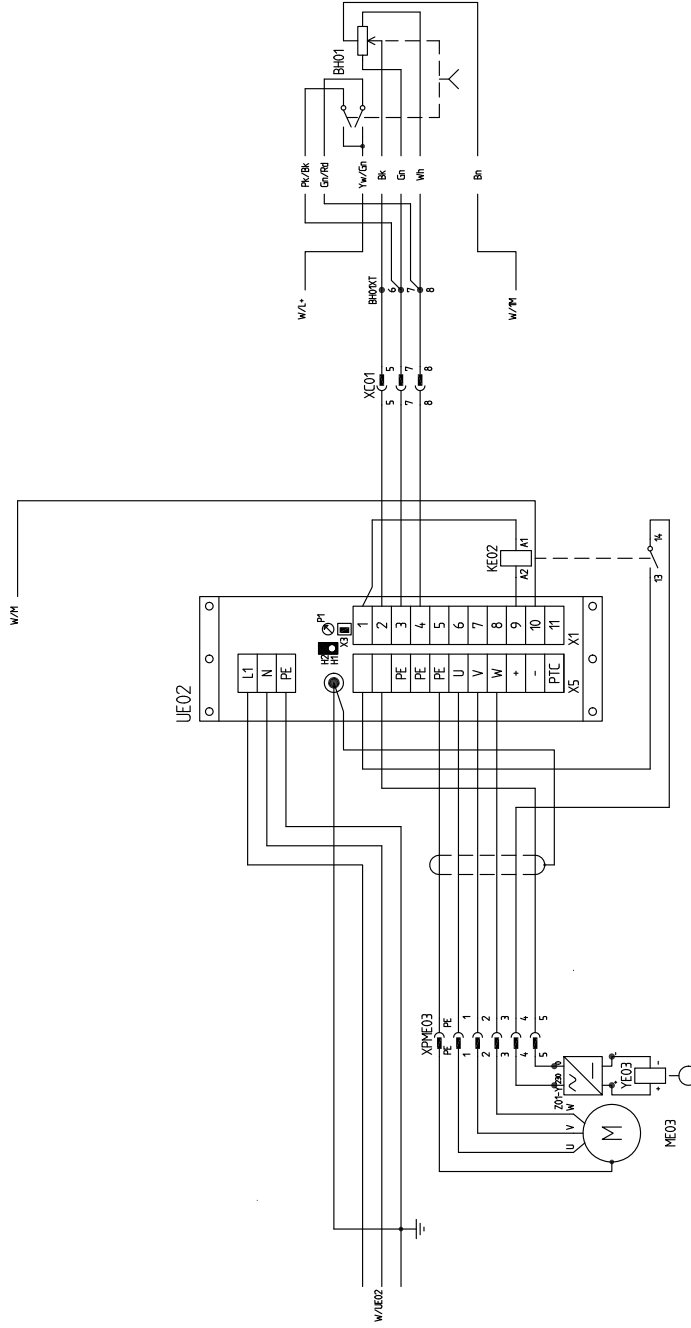

UE02 730792

KE02 730791

Powerdrive electric

4 Service and maintenance

A general review and functional control tests are performed on a regular basis during commissioning.

All service and maintenance shall be recorded. The user should make sure that material for the purpose is easily available.

NOTE: Make sure that damaged components are replaced immediately in order to avoid possible personal and material damage.

Do not connect the equipment until the workplace is cleaned. This is important for the comfort and well-being of personnel and facilitates service and maintenance. Dirt gives a clear indication of the equipment not being properly maintained, which may possibly affect the remaining guarantees on the equipment.

Maintenance safety instructions

The prescribed procedures and service intervals, including those concerning the replacement of parts/accessories, are described in the instruction manual and must be followed. Professionals are the only persons who are allowed to carry out such procedures.

Staff members with appropriate competence and authority are the only persons who are allowed to carry out mechanical and electrical repair and maintenance work. Unauthorised persons should be prohibited to work with machines and devices inside the equipment.

The equipment should be disconnected and secured against unintentional or unauthorised use, including reconnection, during all repair and maintenance work.

It should be confirmed that the equipment is free from voltage before any work on electric equipment is commenced.

Make sure that:

- The main power supply is disconnected
- Moving parts are stationary and locked
- Moving parts cannot move accidentally during maintenance work
- It is not possible to accidentally reconnect the power supply during maintenance and repair work

Use safe and environmentally friendly maintenance products and spare parts!

Directions for work during operation

The user or the "authorised person" must, in each individual case, ensure that the work in question can be carried out without any risk of personal injury because of specific local conditions.

To prevent accidents, only approved and suitable tools and aids may be used during maintenance, adjustment and repair work.

Do not touch rotating parts. Maintain an adequate safe distance between yourself and the machinery to prevent clothes, limbs and hair from becoming caught.

Avoid the occurrence of naked flame, extreme heat (e.g. welding) and sparks in the presence of volatile cleaning materials and nearby inflammable or heat-sensitive materials (e.g. wood, plastics, oils, fats and electric equipment). This can result in fire hazard, harmful gases and damaged insulation.

Directions for work with electric equipment

Use only original fuses with the appropriate rating. The equipment should be stopped immediately on discovery of faults related to the electric power supply.

Defect fuses must not be repaired or bypassed and should only be replaced with fuses of the same kind.

Work on electric equipment and electric components or parts must be carried out by an electrician or authorised staff in accordance with current electric safety regulations.

The parts of the equipment on which inspection, maintenance, and repair work is to be carried out should be disconnected from the power supply.

The electrical equipment should be inspected regularly. Deficiencies, such as loose connections, should be rectified without delay.

When it is necessary to work with live parts, a second member of staff, whose responsibility it is to activate the emergency stop and deactivate the main switch in case of an emergency, should be called in. Isolate the work area with a red/white chain or tape and warning signs. Use only voltage-insulated tools.

Electric connectors must be free of voltage (exemptions include socket-outlets, unless safety precautions state that these are dangerous to be in contact with) before they are disconnected or connected.

4.1 Service record

















































The protocol is an acknowledgement that the equipment has been serviced according to Movomech's instructions and must be filed by the customer.

Place:

Date:

Equipment number:

Service technician:

		Interval in months at 1 shift	Interval in months at >1 shift		
10	Mechanical	4	3	    	<p> Visual inspection, examine whether the product exhibits damages</p> <p> Auditory inspection, examine whether the product exhibits discordant sound</p> <p> Physical inspection, examine whether the product exhibits damages</p> <p> Mechanical inspection, examine whether the product exhibits decomposition, instrument is needed</p> <p> Additional information available</p> <p>* If applicable</p> <p>The service is performed considering the maintenance safety instruction.</p> <p><i>Comment:</i></p>
11	Fasteners	4	3	  	
12	Motor	4	3	    	
13	Driving wheel	4	3	    	
14	Wheels	4	3	    	
20	Elektrical	4	3	   	
21	Fasteners	4	3	  	
22	Cable run	4	3	  	
30	Control unit	4	3	    	
31	Joystick	4	3	  	
32	Emergency stop	4	3	  	

The equipment has been serviced according to the instructions:

.....
Place, date and signature of the service technician

Additional information

10	Mechanical	General overview
12	Motor	<p>Check if gear box is leaking. Approved lubricant for refilling: <u>AGIP</u>: TELIUM VFS320 <u>SHELL</u>: TIVELA OIL SC320 Amount: 0,04 l</p> <p>Check cabling and connections.</p> <p>Test: Drive the unit in both directions, the motor must respond instantly when joystick is affected. Run both top speed and creep rate.</p>
13	Driving wheel	<p>When adjustment is necessary:</p> 
14	Wheels	Check that the trolley runs quietly and easily along the entire runway.
20	Elektrical	General overview
30	Control unit	General overview
31	Joystick	Test: Drive the unit in both directions, the motor must respond instantly when joystick is affected. Run both top speed and creep rate.
32	Emergency stop	Test: Drive the hoist in both directions, activate the emergency stop button, the hoist must stop instantly when the button is activated. The button must remain activated after being affected (reset by turning button).

4.2 Troubleshooting

	Type of problem	Probable cause	Action
A1	No traversing motion	Power failure	Check whether there is a power supply failure, some procedure may be performed by authorized maintenance staff. Reset the power supply
A2		Emergency stop activated	Check whether emergency stop for some reason has been activated, if no risk what so ever occurs when resetting the stop. Reset emergency stop
A3		Defective control unit	Check whether the drive unit has power, inspect the control unit, some procedure may be performed by authorized maintenance staff. Repair control unit
A4		The drive unit is exposed to mechanical obstacle	Check whether some part of the drive unit or load including any object, are stuck in other equipment. Remove mechanical obstacle
B5	Incorrect operating range	Equipment serving as working range limit out of position	Check whether the equipment is damaged. Repair the equipment
C1	Irregular or jerky hoisting motion up/down	The drive unit is exposed to mechanical obstacle	Check whether some part of the drive unit or load including any object, are stuck in other equipment. Remove mechanical obstacle
C2		Driving wheel is worn out	Change driving wheel
C3		Trolley wheels are worn out	Change wheels